



Notching machine 35-0

Maximum cutting capacity

Thickness: 2pt

Type of notch

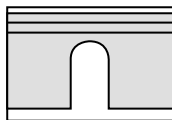

 **Wahlquist**

Notching machine 35-0



Notching machine 35-0 make notches with a round top in 2 pt medium hard steel rules. As standard the machine is equipped with a tool for 8 mm wide and 17 mm deep notches.

Optional tools for 4, 6 and 10 mm wide notches are available.

Dimensions

Height	130 mm
Length	700 mm
Width	300 mm
Weight	12 kg

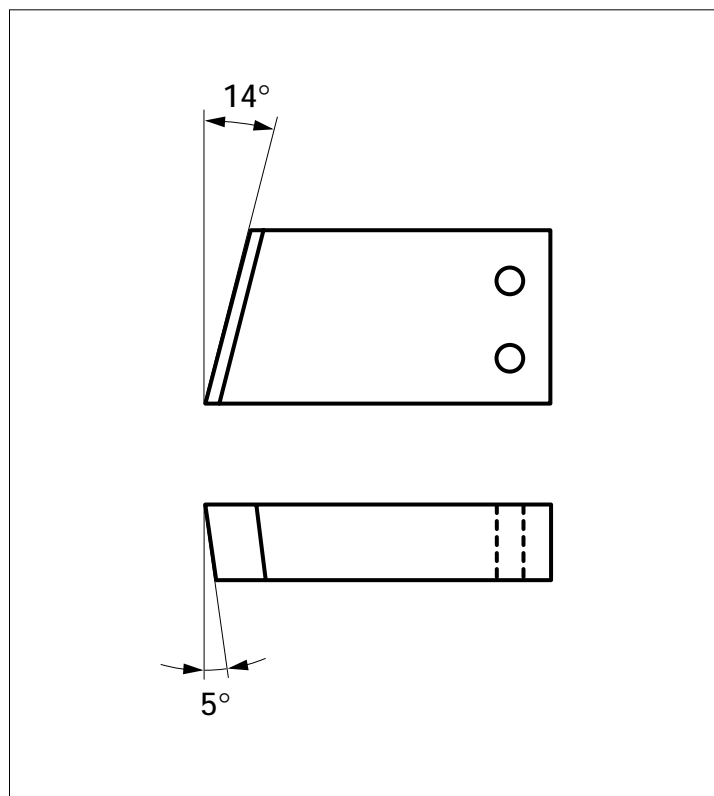

Figure 1

Maintenance

Regrind the tools when necessary and before they are blunt. Respect the original grinding angles. See figure 1.

Lubricate the tools daily with some very thin oil.



AB Wahlquists Verkstäder, Box 1065, SE-581 10 Linköping, Sweden

Phone +46 13 25 24 00, Fax +46 13 25 24 10, E-mail dieproducts@wahlquist.se, www.wahlquist.se